

Assembly Instructions

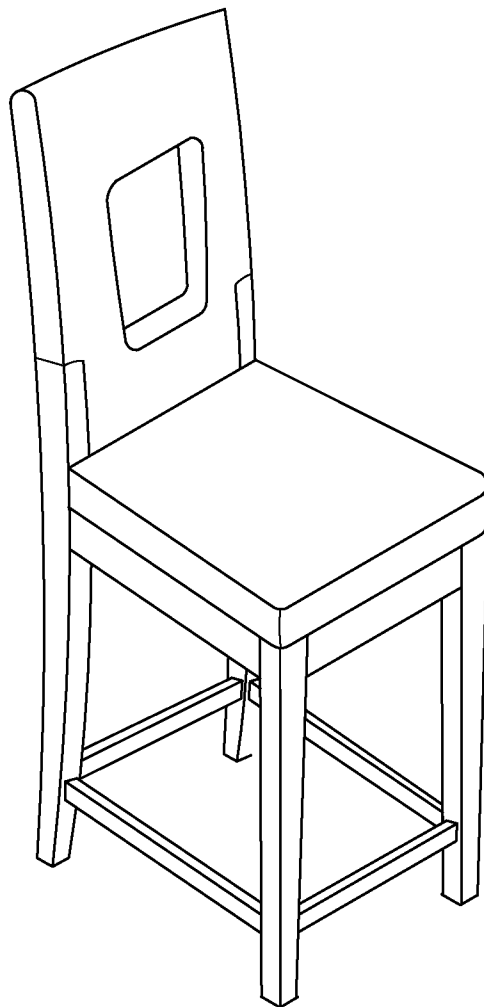

ASSEMBLY RATING

The Assembly Rating is a 5-point system that shows the degree of effort needed in assembling a specific product (with 1 being easy and 5 being relatively difficult). For some products, two persons are recommended.



Do not tighten screws until completely assembled.

PARTS IDENTIFICATION

| NO | PART | SKETCH | Q'TY |
|----|-----------------|--------|------|
| 1 | LELT&RIGHT LEG | | 2PCS |
| 2 | FRONT STRETCHER | | 1PC |
| 3 | LEFT STRETCHER | | 1PC |
| 4 | RIGHT STRETCHER | | 1PC |
| 5 | SEAT FRAME | | 1PC |
| 6 | CHAIR BACK | | 1PC |

HARDWARE LIST

| NO | SHAPE | SPECIFICATION | QTY |
|----|-------|------------------------------------|------|
| A | | $\varnothing\frac{5}{16}$ "*3-1/2" | 4PCS |
| B | | $\varnothing\frac{5}{16}$ "*2" | 1PC |
| C | | $\varnothing\frac{5}{16}$ "*2-1/2" | 4PCS |
| D | | $\varnothing\frac{5}{16}$ " | 9PCS |
| E | | $\varnothing\frac{5}{16}$ "*22MM | 9PCS |
| F | | $\varnothing 10$ *35MM | 2PCS |
| G | | 5MM | 1PC |
| H | | $\varnothing 4$ *38 | 6PCS |

STEP:1

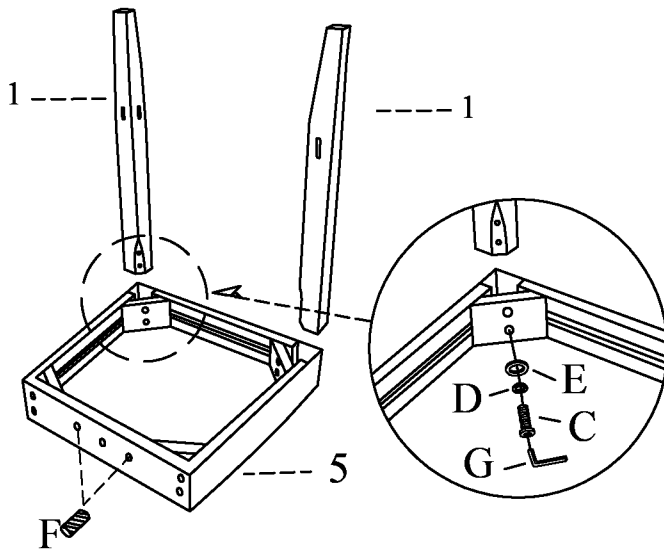

STEP:2

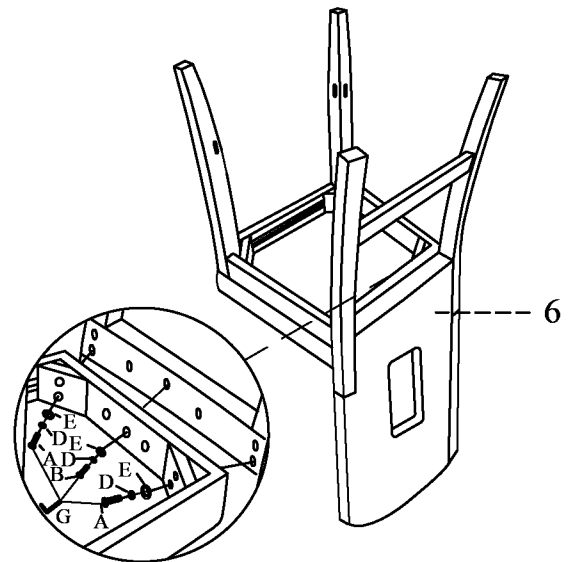

STEP:3

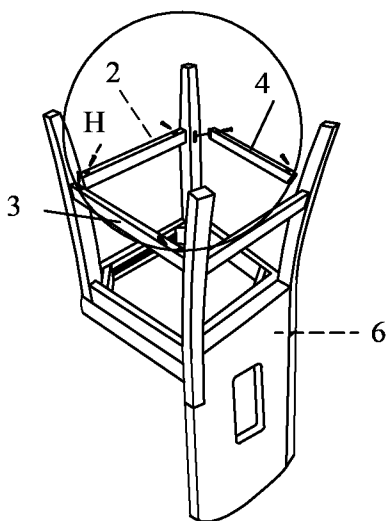

STEP:4

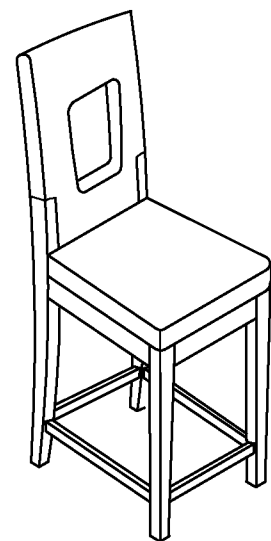

Tip: Tighten screws once the chair is on the spot where you decided be to use.

Do not tighten screws until completely assembled.